

Modular Cooking Range Line thermaline 90 - 4 Zone Induction Top on Oven, 2 Sides H=800

ITEM # _____

MODEL # _____

NAME # _____

SIS # _____

AIA # _____

589670 (MCINFCJ8AO)

Induction Top, 4 zones, two-side operated, on Oven

Short Form Specification

Item No.

Unit constructed according to DIN 18860_2 with 20 mm drop nose top. Internal frame for heavy duty sturdiness in stainless steel. 2 mm top in 1.4301 (AISI 304). THERMODUL connection system enables seamless worktop when units are connected and avoids soil penetrating. Smooth glass ceramic surface without any "dead" spots allows for quick and easy cleaning. Features 9 power levels with fast deployment to full heating power and very low heat dissipation to the kitchen. Overheat protection switches off the supply in case of overheating. Metal knobs with embedded hygienic silicon "soft" grip enable easier handling and cleaning. Passthrough electric static oven base with 40 mm thick oven door and ribbed enamelled steel base plate. Constructed according to 1.4301 (AISI 304). Oven chamber with 2 levels of runners for 2/1 GN shelves to enable simultaneous and faster cooking. Heavy duty thermostat with temperature range up to 300°C, electronic sensor for precise temperature control and manual humidity control in the cooking chamber. Upper heating element can also be used for grilling, with or without ventilating mode. Overheat protection switches off the supply in case of overheating. Standby function saves energy and quickly recovers maximum power. Metal knobs and oven handles ergonomically designed with embedded hygienic silicon "soft" grip enable easier handling and cleaning.

Main Features

- Fast deployment with full heating power immediately.
- Low heat dissipation to the kitchen.
- Overheat protection: a temperature sensor switches off the supply in case of overheating.
- Pans can easily be moved from one area to another without lifting.
- The smooth glass-ceramic surface can be quickly and easily cleaned, thus providing maximum hygiene.
- IPX5 water resistance certification.
- All major components may be easily accessed from the front.
- THERMODUL connection system creates a seamless work top when units are connected to each other thus avoiding soil penetrating vital components and facilitating the removal of units in case of replacement or service.
- Metal knobs with embedded hygienic silicon "soft" grip for easier handling and cleaning. The special design of the controls prevent infiltration of liquids or soil into vital components.
- 9 power levels.
- Large visible digital display manufactured in tempered glass to resist heat and chemicals, showing temperatures or power settings. The display also shows on/off status of the appliance and on/off status of the heating elements.
- Unit constructed according to DIN 18860_2 with 70 mm recessed plinth.
- 40 mm thick oven door for heat insulation.
- Handles are ergonomically designed with silicon "soft" grip for easy handling and cleaning.
- Oven chamber to have 2 levels of runners to accommodate 2/1 GN trays and ribbed enamelled steel base plate.
- The upper heating element of the oven can also be used for grilling.
- Manual control of humidity in cooking chamber.
- Electronic sensor for precise temperature control.
- Oven temperature up to 300 °C

Construction

- Control light for each zone.
- 2 mm top in 1.4301 (AISI 304).
- Flat surface construction with minimal hidden areas to easily clean all surfaces
- Unit constructed according to DIN 18860_2 with 20 mm drop nose top.

APPROVAL: _____

- Unit constructed according to DIN 18860_2 with 20 mm drop nose top and 70 mm recessed plinth.
- Internal frame for heavy duty sturdiness in stainless steel.

Sustainability



- Standby function for energy saving and fast recovery of maximum power.
- This model is compliant with Swiss Energy Efficiency Ordinance (730.02).

Included Accessories

- 1 of Grid, chromium plated, for ovens PNC 910652 2/1 GN

Optional Accessories

- Scraper for cook tops PNC 910601
- Baking sheet 2/1 GN for ovens PNC 910651
- Bottom steel plate 2/1 GN for fire clay plate 800&900 with baking oven PNC 910655
- Fire clay plate 2/1 GN for ovens PNC 910656
- Connecting rail kit, 900mm PNC 912502
- Stainless steel side panel, 900x800mm, freestanding PNC 912511
- Portioning shelf, 1000mm width PNC 912528
- Portioning shelf, 1000mm width PNC 912558
- Folding shelf, 300x900mm PNC 912581
- Folding shelf, 400x900mm PNC 912582
- Fixed side shelf, 200x900mm PNC 912589
- Fixed side shelf, 300x900mm PNC 912590
- Fixed side shelf, 400x900mm PNC 912591
- Stainless steel front kicking strip, 1000mm width PNC 912600
- Stainless steel side kicking strips left and right, freestanding, 900mm width PNC 912621
- Stainless steel plinth, freestanding, 1000mm width PNC 912922
- Connecting rail kit: modular 90 (on the left) to ProThermetic tilting (on the right), ProThermetic stationary (on the left) to ProThermetic tilting (on the right) PNC 912975
- Connecting rail kit: modular 80 (on the right) to ProThermetic tilting (on the left), ProThermetic stationary (on the right) to ProThermetic tilting (on the left) PNC 912976
- Endrail kit, flush-fitting, left PNC 913111
- Endrail kit, flush-fitting, right PNC 913112
- Back panel, 1000x550mm, for bases one-side operated PNC 913184
- Endrail kit (12.5mm) for thermaline 90 units, left PNC 913202
- Endrail kit (12.5mm) for thermaline 90 units, right PNC 913203
- Insert profile d=900 PNC 913232
- Side reinforced panel only in combination with side shelf, for freestanding units PNC 913259
- Shelf fixation for TL90 two-side operated PNC 913284

- Filter W=1000mm PNC 913666
- Stainless steel dividing panel, 900x800mm, (it should only be used between Electrolux Professional thermaline Modular 90 and thermaline C90) PNC 913673
- Electric mainswitch 63A 10mm² NM for modular H800 electric units (factory fitted) PNC 913677
- Stainless steel side panel, 900x800mm, flush-fitting (it should only be used against the wall, against a niche and in between Electrolux Professional thermaline and ProThermetic appliances and external appliances - provided that these have at least the same dimensions) PNC 913689

Front

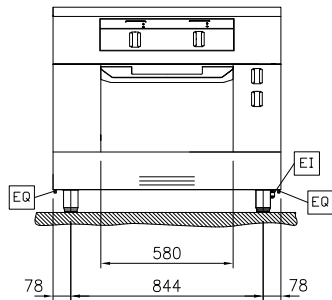

Side

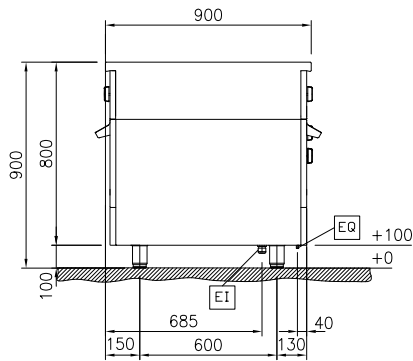

EI = Electrical inlet (power)
 EQ = Equipotential screw

Top

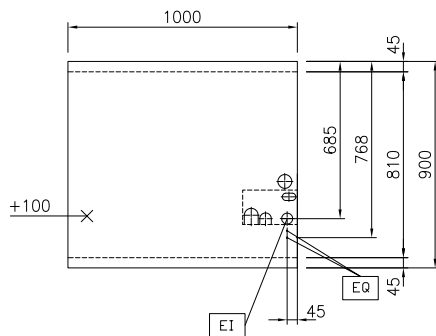

Electric

Supply voltage:

589670 (MCINFCJ8AO) 400 V/3N ph/50/60 Hz

Total Watts:

25 kW

Key Information:

Configuration:	On Oven, Both-Sides Operated
Front Plates Power:	5 - 5 kW
Back Plates Power:	5 - 5 kW
Front Plates dimensions:	320x330 320x330
Back Plates dimensions:	320x330 320x330
Induction Top Dimensions (width):	1000 mm
Induction Top Dimensions (depth):	900 mm
External dimensions, Width:	1000 mm
External dimensions, Depth:	900 mm
External dimensions, Height:	800 mm
Net weight:	197 kg

Sustainability

Current consumption: 39.7 Amps